

# TANK SHEAR GR032



## FEATURES :

The tank shear GR032 is a tool dedicated to the cutting of tanks, reservoirs or sheet metal.

Thanks to its characteristics it can be mounted on 26 to 40 tons carriers.

### A ROBUST BODY

The body perfectly integrates the cylinder and protects it from contacts and from eventual projections.

It has an escape hatch to evacuate materials to direct the projections and to reduce risks.

The perimeter cut allows precise and very efficient work.

A punching spur allows puncturing and facilitates the attack of the cut.

## ADVANTAGES :

- Bolted plate.
- Multi-Motor 360 ° hydraulic rotation.
- Reversed cylinder, rod protected in the frame.
- Speed valve.
- HLE steel structure and anti abrasion.
- Drill spur

**SIMPLICITY**

**POWER**

**SPEED**

**ROBUSTNESS**



## TECHNICAL DIAGRAM :

→ F1

→ F2

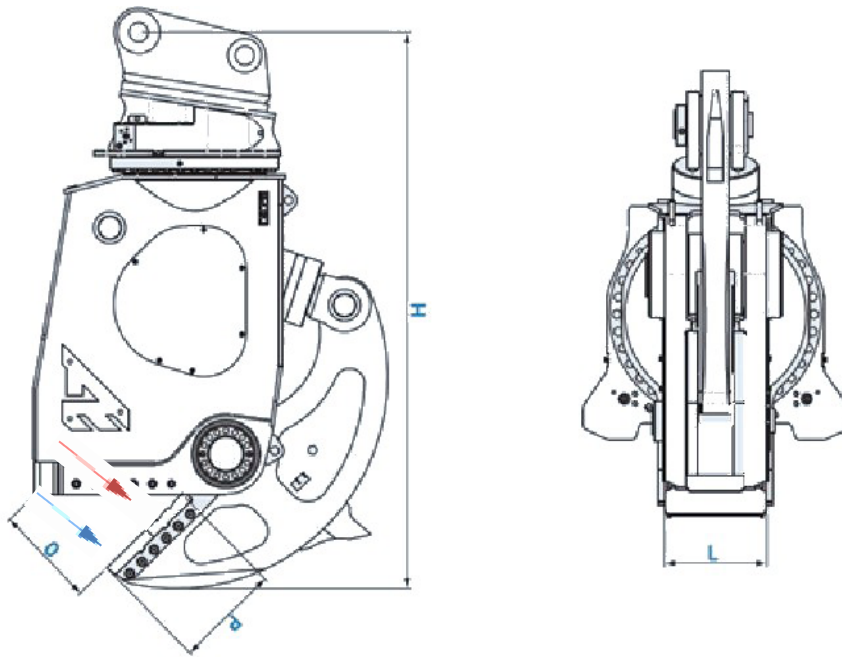

## TECHNICAL SPECIFICATIONS :

Model	Weight	H	O	P	L	F1	F2		Cylinder		Cycle time	Rotation		Carrier
	Kg	mm	mm	mm	mm	t	t	mm	Bar	lt/ min	Sec	Bar	lt / min	t
<b>GR032</b>	3000	2631	483	500	380	490	148	30	380 maxi	400 maxi	3.3	140	28/40	26-40