

BALLAST TRACK REMOVER





The essential tool for your track maintenance operations!

The Arden Equipment ballast cleaner is a hydraulic tool developed to meet the specific requirements of railway ballast cleaning operations. Designed to fit rail/road excavators from 16 to 22 tonnes, it is indispensable for removing clogged ballast.

Advantages

- ✓ Its significant weight enables deep ballast cleaning very quickly.
- ✓ Adjustable stops allow precise working depth adjustment, helping to preserve the track bed.
- ✓ The sliding elements are mounted on high-quality synthetic bushes that eliminate the need for lubrication and ensure effective shock absorption.
- ✓ The two contact points with the track are electrically insulated by plastic bushes.
- ✓ The end bearings are easily removable.



			
t	Kg	bar max	l/mn
16-22	2100	250	100/140

Technical drawing

(data in mm)

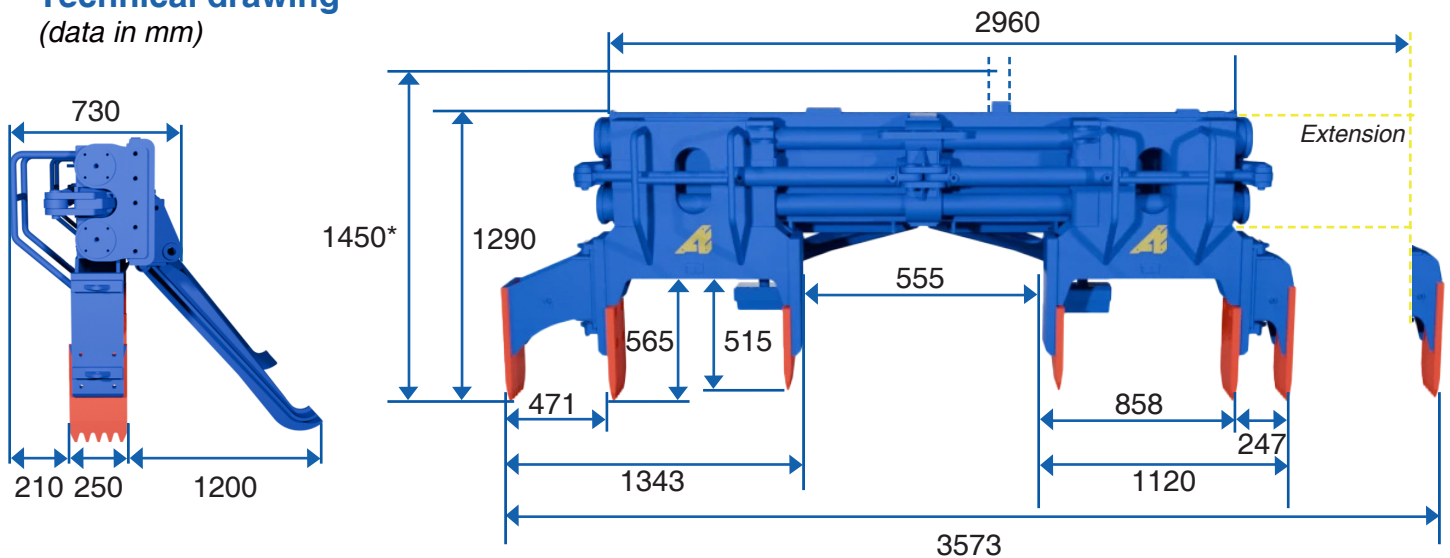

* These data are provided for information purposes only and may vary depending on configurations.

Technical data and visuals are non-contractual and subject to change without prior notice.



+33 (0)3 24 33 64 30



contact@arden-equipment.com



9 Avenue de l'Industrie FR - 08000 Charleville-Mézières



www.arden-equipment.com

