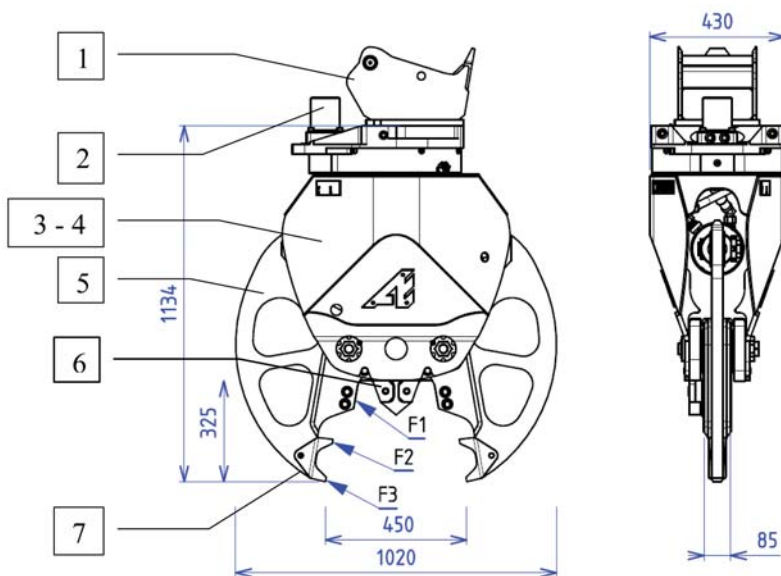

CU 350

Multiprocesador Universal con cambio rápido de Mandíbulas

F1
F2
F3

	kg	t	t	t	bar	l/mn	Bar(max)	l/mn	t
CU 350 CB	370	95	45	32	100	15	270	40/80	3,5/7

F1
F2
F3

	kg	t	t	t	bar	l/mn	Bar(max)	l/mn	t
CU 350 CF	415	-	62	39	100	15	270	40/80	4/7

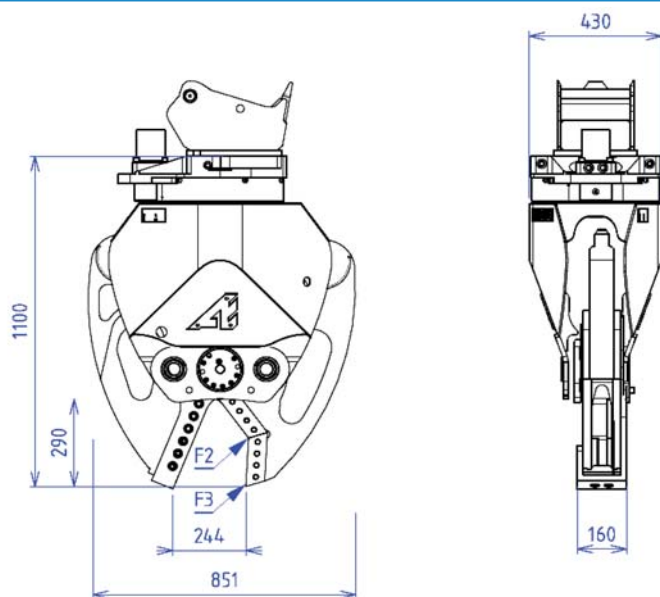

Peso sin cabezal.

- 1 Cabezal a abulonar.
- 2 Giro 360° Hidráulico o Libre.
- 3 Cilindro horizontal totalmente protegido dentro del cuerpo.
- 4 Cuerpo en acero de Alta Resistencia Elástica. Ejes tratado HF.
- 5 Juego de Mandíbulas en acero Hardox 450 con corte de varillas.
- 6 Cuchillas reversibles.
- 7 Dientes amovibles.
- 8 Soporte de Mandíbulas.
- 9 Cambio de Mandíbulas rápido en 30 minutos con dos operadores.

I IPE	I IPN	UPN	●
mm	mm	mm	mm
120	100	120	30