

CU 350

Cisaille universelle à changement rapide d'outil

F1
F2
F3

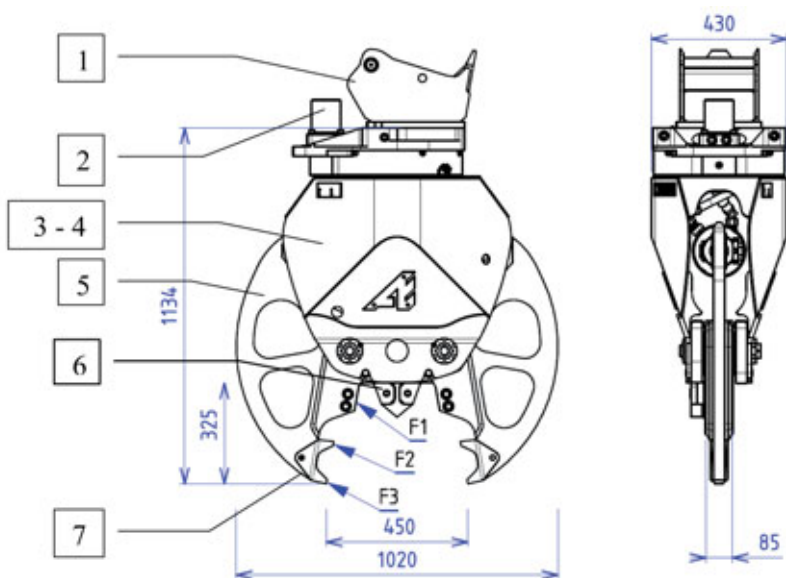

	kg	t	t	t	bar	l/mn	Bar(max)	l/mn	t
CU 350 CB	370	95	45	32	100	15	270	40/80	3,5/7

F1
F2
F3

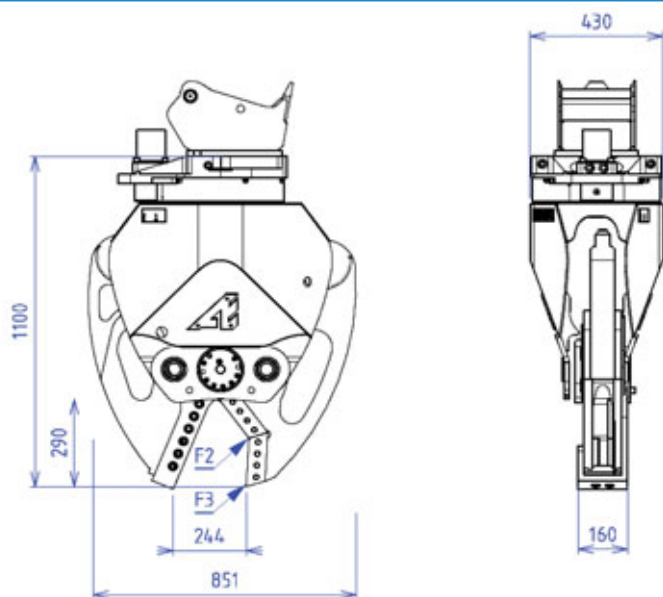
	kg	t	t	t	bar	l/mn	Bar(max)	l/mn	t
CU 350 CF	415	-	62	39	100	15	270	40/80	4/7

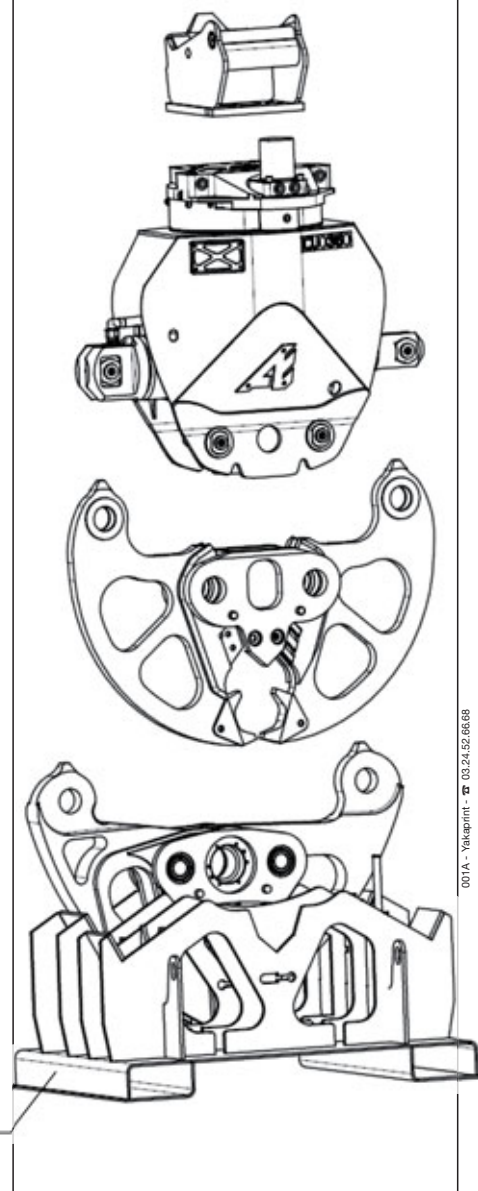

- 1 Platine boulonnée.
- 2 Rotation 360° hydraulique ou libre.
- 3 Vérin horizontal intégré dans le bâti (protection complète).
- 4 Bâti en acier HLE. Axes traités HF.
- 5 Jeux de mâchoires en acier 450 HB avec coupe rond intégré.
- 6 Lames réversibles.
- 7 Pièces d'usures amovibles.
- 8 Support Mâchoires.
- 9 Changement mâchoires rapide en 30 min à 2 opérateurs.



I IPE	I IPN	UPN	●
mm	mm	mm	mm
120	100	120	30

Les poids sont donnés sans platine boulonnée.